

SYNTHESIS

The implications of nongenetic inheritance for evolution in changing environments

Russell Bonduriansky,¹ Angela J. Crean¹ and Troy Day^{2,3}

1 Evolution & Ecology Research Centre and School of Biological, Earth and Environmental Sciences, University of New South Wales, Sydney, NSW, Australia

2 Department of Mathematics and Statistics, Queen's University, Kingston, ON, Canada

3 Department of Biology, Queen's University, Kingston, ON, Canada

Keywords

adaptation, climate change, conservation biology, conservation genetics, epigenetics, evolutionary theory, phenotypic plasticity.

Correspondence

R. Bonduriansky, Evolution & Ecology Research Centre and School of Biological, Earth and Environmental Sciences, University of New South Wales, Sydney, NSW 2052, Australia.

Tel.: +61-2-9385-3439

fax: +61-2-9385-1558;

e-mails: r.bonduriansky@unsw.edu.au;

a.crean@unsw.edu.au; tday@mast.queensu.ca

Received: 29 September 2011

Accepted: 6 October 2011

First published online: 8 November 2011

doi:10.1111/j.1752-4571.2011.00213.x

Abstract

Nongenetic inheritance is a potentially important but poorly understood factor in population responses to rapid environmental change. Accumulating evidence indicates that nongenetic inheritance influences a diverse array of traits in all organisms and can allow for the transmission of environmentally induced phenotypic changes ('acquired traits'), as well as spontaneously arising and highly mutable variants. We review models of adaptation to changing environments under the assumption of a broadened model of inheritance that incorporates nongenetic mechanisms of transmission, and survey relevant empirical examples. Theory suggests that nongenetic inheritance can increase the rate of both phenotypic and genetic change and, in some cases, alter the direction of change. Empirical evidence shows that a diversity of phenotypes – spanning a continuum from adaptive to pathological – can be transmitted nongenetically. The presence of nongenetic inheritance therefore complicates our understanding of evolutionary responses to environmental change. We outline a research program encompassing experimental studies that test for transgenerational effects of a range of environmental factors, followed by theoretical and empirical studies on the population-level consequences of such effects.

Introduction

Many regions of the world are currently undergoing rapid, anthropogenic environmental change, involving both biotic factors such as species-community composition (Lavergne et al. 2010), and abiotic factors such as climate (McMahon et al. 2011) and environmental chemistry (Lurling and Scheffer 2007; Robertson et al. 2007). While the causes of these environmental changes are rooted in human demography, economics and politics, evolutionary biologists and ecologists recognize a need to understand the consequences of environmental change for the fate of particular natural populations, and biodiversity as a whole (McMahon et al. 2011). A key question motivating this research program is whether or not populations will be able to adapt rapidly enough to avoid extinction (Visser 2008).

Efforts to model adaptation rates typically focus on allelic variation and Mendelian inheritance (e.g. Blows and Hoffmann 2005; Gomulkiewicz and Houle 2009; Hoffmann and Sgrò 2011), but environmentally generated variation can also influence the rate and direction of adaptation (Jablonka and Lamb 1995; West-Eberhard 2003). It has been recognized for many years that within-generation phenotypic plasticity is likely to play an important role in allowing populations to persist through periods of rapid environmental change (Baldwin 1896; Lloyd Morgan 1896; Charmantier et al. 2008; Lande 2009; Chevin et al. 2010; Nicotra et al. 2010). Even if a population cannot keep pace with a rapidly changing environment through genetic changes (i.e., 'evolution' *sensu stricto*), facultative phenotypic changes within each generation can bring individuals closer to the phenotypic optimum. The adaptive role of plasticity in a rapidly

changing environment has been questioned, however, because plastic responses can be maladaptive when environments are highly unpredictable (Reed et al. 2010), or conditions fall outside the range to which the population has had an opportunity to adapt (Visser 2008).

In addition to within-generation phenotypic plasticity, transgenerational effects of environment mediated by nongenetic mechanisms of inheritance could influence the rate and direction of adaptation (Jablonka and Lamb 1995; Lachmann and Jablonka 1996; Pál 1998; Pál and Miklós 1999; Jablonka and Lamb 2005; Bossdorf et al. 2008; Day and Bonduriansky 2011). Empirical studies show that variation in many traits is transmitted across generations by nongenetic inheritance mechanisms, sometimes in combination with genetic (i.e., allelic) inheritance (Jablonka and Lamb 1995, 2005), and theory suggests that the nongenetic component can influence the rate and direction of both phenotypic and genetic change (Laland et al. 1999; Richerson and Boyd 2005; Laland et al. 2010; Day and Bonduriansky 2011). However, because few empirical studies have examined ecologically important traits within realistic environmental contexts (Bossdorf et al. 2008; Bossdorf and Zhang 2011), and theoretical predictions largely await empirical testing, the role and importance of nongenetic inheritance in adaptation remain poorly understood.

Here, we review theoretical studies that have examined the role of nongenetic inheritance in population persistence and adaptation in changing environments. We also provide an overview of empirical examples illustrating the diversity of known transgenerational effects. We discuss outstanding questions, and suggest fruitful approaches for further research.

Models of the role of nongenetic inheritance in adaptation

We have previously defined nongenetic inheritance as the transmission to offspring of components of the parental phenotype or environment, which can be regarded as the 'interpretative machinery' of gene expression (Bonduriansky and Day 2009; Day and Bonduriansky 2011). Nongenetic inheritance therefore comprises a variety of proximate mechanisms, such as the transmission of epigenetic variation (i.e., DNA-methylation patterns, chromatin structure or RNA), parental glandular secretions (e.g., milk), nutrients (e.g., yolk), hormones, or behaviors to offspring, and encompasses phenomena such as maternal/paternal effects, vertical (parent-offspring) indirect genetic effects, vertical components of niche construction, and cultural inheritance (Jablonka and Lamb 1995, 2005; Bonduriansky and Day 2009). Nongenetically transmissible phenotypic variants can be of two types. First, the

transmissible phenotype can be induced by environmental conditions (i.e., 'acquired traits'). For example, in some organisms, anti-predator defences induced by exposure to predator cues can be transmitted to offspring (Agrawal et al. 1999). Second, the transmissible phenotype can arise spontaneously, without obvious environmental triggers (see Lachmann and Jablonka 1996). For example, at least some transmissible epigenetic variation is believed to arise via random changes in DNA-methylation patterns (Richards 2006; Vaughn et al. 2007). Nongenetic inheritance thus comprises a range of mechanisms whereby parents can influence the phenotypes of their offspring, and represents an extension of the Mendelian-genetic model of inheritance.

Nongenetic inheritance can be viewed as an extension of plasticity across generations ('transgenerational plasticity'). Conventional (within-generation) plasticity is a genetic mechanism that allows a genotype to produce different phenotypes in different environments, either via changes in the ontogenetic program that lead to a different phenotypic end-point (developmental plasticity), or as an environment-dependent response within a developmental stage (phenotypic plasticity). A genotype thereby specifies a norm of reaction that relates the expression of a phenotypic trait to an environmental parameter (Baldwin 1896; Lloyd Morgan 1896; West-Eberhard 2003). However, environmental conditions experienced by a parent can also influence aspects of its phenotype that affect the development of its offspring, and such transgenerational effects can constitute nongenetic inheritance of an 'acquired trait' (Visser 2008; Bonduriansky and Day 2009; Reed et al. 2010). For example, an individual that acquires abundant resources (i.e., high condition) from its environment may pass extra resources to its offspring in yolk or milk, and thereby enhance the condition of its offspring. The effects of an environmental factor are typically similar in both the individuals that experience the environment and in their offspring (Qvarnström and Price 2001; Bonduriansky and Head 2007), but cases have been reported of effects of opposite sign (Janssen et al. 1988) or on different traits in parents and offspring (Pembrey et al. 2006).

While many studies have addressed the role of plasticity in evolution (reviewed in West-Eberhard 2003; Lande 2009), only a few studies have focused explicitly on the potential role of nongenetic inheritance. Theory on the role of nongenetic inheritance in adaptation to a changing environment has addressed two questions: First, can nongenetic inheritance enable a population's mean phenotype to track a changing environment whose temporal trend or fluctuations are too rapid for genetically based adaptation? Second, how does selection act on nongenetic inheritance itself within the context of a changing environment? Below, we provide an overview of this body of

theory, and discuss its major conclusions and limitations. We do not discuss the extensive literature on niche-construction, which encompasses phenomena that extend beyond the purview of inheritance (Laland et al. 1996, 1999; Odling-Smee et al. 2003).

Jablonka et al. (1992) used simple models of nongenetic ('epigenetic') inheritance in asexual and sexual organisms to show that nongenetic inheritance can be advantageous as a form of adaptive transgenerational plasticity in a changing environment: if environmental conditions fluctuate in a predictable manner, then parents will benefit by producing offspring whose phenotypes are optimized for the anticipated conditions. Jablonka et al. (1995) further showed, using analytical results and numerical simulations, that the transmission of plastic responses to offspring (i.e., nongenetic inheritance) can be more advantageous than within-generation plasticity alone. This is because within-generation plasticity requires each individual to assess and respond to an environmental cue, resulting in a lag time before the optimal phenotype is expressed, whereas nongenetic inheritance can reduce this lag (following the first generation of exposure) by allowing offspring to express the optimal phenotype immediately. However, Paenke et al. (2007) found that nongenetic inheritance is disadvantageous when environmental fluctuations are very rapid and unpredictable from current environmental cues. When parental environment provides a poor predictor of offspring environment, nongenetic inheritance can be maladaptive because the mismatch of transgenerational effects to the environment experienced by offspring can interfere with adaptive plastic responses by the offspring themselves.

Pál (1998) and Pál and Miklós (1999) modeled the roles of nongenetic inheritance in adaptation to a novel environment where the population-mean phenotype is far from the optimum. They found that, like within-generation plasticity, nongenetic inheritance can be advantageous because adaptation can proceed initially through transmission of advantageous phenotypic variants. Near the optimum, however, they concluded that selection acts to suppress plasticity and nongenetic inheritance, resulting in genetic assimilation (i.e., evolution of environment-independent expression) of the optimal phenotype. This is because, although some nongenetically transmitted variants can be stable over many generations (Anway et al. 2005; Richerson and Boyd 2005; Johannes et al. 2009), genetic inheritance is likely to provide greater long-term stability of the optimal phenotype. Pál and Miklós (1999) further concluded that nongenetic inheritance can facilitate a shift into a novel niche because transmissible phenotypic variants that arise independently of genetic change will augment phenotypic variation around the local fitness peak (i.e., the phenotypic

optimum within the current niche). If some phenotypic variants approach an alternative fitness peak (i.e., the phenotypic optimum within an alternative niche), selection will increase their frequency via nongenetic inheritance and, subsequently, selection in the new niche will favor genetic assimilation of the optimal phenotype via fixation of alleles that bring about the favored phenotype without environmental induction or nongenetic transmission from parents. This finding is analogous to the conclusion that within-generation plasticity can facilitate niche-shift simply by increasing the amount of (random) phenotypic variation, thereby 'smoothing' the fitness landscape and thus making it easier for populations to evolve away from their local fitness peak (Whitlock 1995; Borenstein et al. 2006).

Day and Bonduriansky (2011) built evolutionary models based on a combination of genetic and nongenetic inheritance. They showed that nongenetic mechanisms such as transgenerational epigenetic effects, indirect genetic effects, RNA-mediated inheritance and cultural inheritance can interact with genetic variation, and influence the rate of response to selection as well as the equilibrium allele frequency and mean phenotype. In particular, a population can undergo rapid adaptation via the spread of advantageous nongenetically transmitted variants (whether these arise as facultative plastic responses in the parents, or as random phenotypic changes that contribute to the pool of heritable variation). In populations faced with novel environments, nongenetic inheritance can thus, in principle, effect change over generations in the population-mean phenotype, as well as influence the dynamics and direction of genetically based evolution.

Whereas the aforesaid models assumed the existence of nongenetic inheritance and asked how it might affect evolution, Lachmann and Jablonka (1996) modeled the evolution of a nongenetic inheritance mechanism itself. They found that the optimal stability of nongenetically transmitted variants across generations depends on environmental periodicity, with greater stability favored when fluctuations span a greater number of generations. Interestingly, they showed that, in environments that fluctuate on time-scales longer than the generation time but not long enough for adaptation through genetic change, the optimal form of nongenetic inheritance is neither the transmission of variants induced rapidly by current conditions, nor the transmission of variants that arise spontaneously without environmental induction. Rather, in such cases, selection favors an intermediate degree of stability where variants induced by environment decay slowly over generations in the absence of the inducing environment. They also note that selection will favor trait-specific rather than generalized mechanisms of nongenetic inheritance.

A diverse set of models thus suggest that the presence of nongenetic inheritance can affect the fate of populations confronted by changing environments. Nongenetic inheritance can contribute to the pool of heritable phenotypic variation on which selection can act (Pál 1998; Pál and Miklós 1999). In populations faced with a predictably fluctuating environment, nongenetic inheritance can allow for adaptive transgenerational effects, whereby parents can optimize the phenotypes of their offspring for the environment that the offspring are likely to encounter (Jablonka et al. 1992, 1995). In populations faced with a long-term environmental trend, such as increasing temperature, selection is expected to increase the frequency of beneficial nongenetically transmitted variants, resulting in adaptive change in the population-mean phenotype over multiple generations (Pál and Miklós 1999; Day and Bonduriansky 2011). In other words, nongenetic inheritance can decouple phenotypic change from genetic change over multiple generations, thus allowing populations to respond to selection even in the absence of genetic variation for traits affecting fitness. Moreover, by influencing selection on genes, nongenetic inheritance can also affect the rate and direction of genetically based evolution (Laland et al. 1996; Richerson and Boyd 2005; Bonduriansky and Day 2009).

An important but rarely acknowledged assumption of all the models outlined earlier, however, is that nongenetic inheritance mechanisms mediate the transmission to offspring of phenotypic variants that are immediately or at least potentially adaptive. Although the possibility of such effects is supported by empirical evidence, empirical studies also show that nongenetic inheritance can allow

for the transmission of acquired pathological states that are likely to be detrimental in any environment. Given the potential for anthropogenic changes such as pollution to engender transgenerational pathologies, theory must also address the consequences of such phenomena for population persistence and adaptation.

Empirical evidence

In the following paragraphs, we outline some examples of nongenetically transmitted phenotypes that have the potential to affect population persistence and adaptation in the face of rapid environmental change. These examples are summarized in Table 1.

Temperature

Although nongenetic (especially epigenetic) inheritance has been studied most extensively in plants (Jablonka and Lamb 1995; Johannes et al. 2009; Teixeira et al. 2009; Roux et al. 2011), the transgenerational effects of changes in temperature have rarely been empirically tested. Warm temperatures in the parental environment conferred a competitive advantage in *Arabidopsis thaliana*: plants grown in warm temperatures produced seeds that had significantly higher nitrogen content, and resulted in offspring that had increased germination rate, biomass, and seed production at all rearing temperatures (Blodner et al. 2007). This suggests that nongenetic inheritance may help *Arabidopsis* populations prosper under a warming climate. Conversely, Kochanek et al. (2010) suggest that parental effects may have negative consequences for population

Table 1. Examples of environmental factors that can have transgenerational effects, the nature of those effects on offspring, and their consequences for offspring fitness.

Environmental factor	Transgenerational effect	Consequences for offspring fitness	Species	References
Increased temperature	Increased germination, biomass and seed production	Positive	<i>Arabidopsis thaliana</i>	Blodner et al. (2007)
	Decreased seed longevity	Negative	<i>Wahlenbergia tumidifruca</i>	Kochanek et al. (2010)
Altered habitat	Increased tolerance and competitive ability	Positive and negative	<i>Drosophila melanogaster</i>	Zamudio et al. (1995); Gilchrist and Huey (2001); Crill et al. (1996)
	Reduced size			
Altered habitat	Novel foraging technique	Positive	<i>Ratus ratus</i> , <i>Tursiops</i> sp.	Aisner and Terkel (1992); Krutzen et al. (2005)
Pollution	Increased resistance	Positive and negative	<i>Bugula neritina</i> , <i>Fundulus heteroclitus</i>	Marshall (2008); Moran et al. (2010); Nye et al. (2007)
High-fat diet	Increased size, reduced insulin sensitivity	Negative	<i>Mus musculus</i>	Dunn and Bale (2009)
	Decreased longevity, disease		<i>Homo sapiens</i>	Bygren et al. (2001); Kaati et al. (2002)
Endocrine disruptors	Low fertility, adult disease, altered behavior	Negative	<i>Rattus norvegicus</i>	Anway et al. (2005, 2006a, 2006b); Crews et al. (2007); Skinner et al. (2008)

persistence of *Wahlenbergia tumidifruca*: plants grown in warm-wet, warm-dry, and cool-dry conditions produced offspring with decreased longevity (by a factor of at least 2) in hot temperatures, compared with offspring of plants grown in cool-wet conditions (Kochanek et al. 2010). Increased seed longevity can help to buffer populations from fluctuating environments, and therefore by reducing seed longevity, parental effects in this species may weaken the seed-bank storage effect leaving populations more vulnerable to unpredictable environments (Kochanek et al. 2010).

In *Drosophila*, the temperature experienced by individuals has diverse phenotypic effects on offspring. For example, in *D. melanogaster*, fitness of offspring increased linearly with an increase in the temperature (from 18 to 29°C) experienced by their parents, independently of the temperature experienced by offspring (Gilchrist and Huey 2001). Furthermore, males whose parents were raised at high (25°C) temperature were usually dominant in paired territorial contests over males whose parents were raised at low (18°C) temperature (Zamudio et al. 1995). On the other hand, offspring from mothers reared at 25°C are smaller than offspring from mothers reared at 18°C, and these offspring lay exceptionally small eggs if they also develop at high temperatures (Crill et al. 1996). In *D. serrata*, viability was negatively influenced by parental cold exposure, but grandparental effects on viability were negligible (Magiafoglou and Hoffmann 2003). In addition, female productivity was increased by maternal cold shock, but reduced by grandmaternal cold shock (Magiafoglou and Hoffmann 2003). These empirical examples clearly demonstrate that changes in temperature can influence the phenotype and fitness of descendants, potentially for multiple generations. However, because of the complexity of the responses observed, and lack of knowledge of the proximate mechanisms involved, it is not yet clear how these transgenerational effects will influence population responses to climate change.

Bet-hedging

There is some evidence to suggest that mothers may adaptively adjust within-brood variability of offspring phenotype in unpredictable environments, thereby increasing the likelihood that at least some of their offspring will have the 'right' phenotype in a changing environment (Crean and Marshall 2009). Mothers may also hedge their bets in unpredictable environments by producing offspring of higher quality than would be selected for in stable environments, thereby maximizing the chance of survival in any environment (conservative bet-hedging: Eium and Fleming 2004). Evidence for plasticity in within-brood variance as an adaptive strategy

in unpredictable environments is mainly theoretical (e.g. Marshall et al. 2008; Olofsson et al. 2009), as the indirect and multi-generational benefits of bet-hedging are difficult to quantify empirically. However, the diversity of traits and range of taxa with anecdotal evidence of bet-hedging suggests that it is widespread (Simons 2011), and thus adaptive plasticity in within-brood variability may increase the likelihood that populations will persist under climate change.

Behavioral responses to altered environments

Vertical transmission of behavioral variation (a form of 'social inheritance') may help populations adapt to environmental change if a novel behavior facilitates the use of a novel environment or provides a new way of interacting with the environment (Wcislo 1989; Duckworth 2009). Transmission of learned behavior to offspring enables immediate and adaptive responses to environmental variation, and consequently learned behaviors can allow populations to adapt quickly during periods of rapid environmental change. Some of the strongest evidence for vertical transmission of behavior is cone stripping by Israeli black rats, where cross-fostering experiments showed the ability to strip pine cones efficiently is learned from mothers and not genetically determined (Aisner and Terkel 1992). Another example of behavioral inheritance facilitating the use of novel environmental niches is the matrilineal transmission of tool use in bottlenose dolphins. A subset of the population of bottlenose dolphins in Western Australia carry marine sponges over their rostra like a protective glove while probing the sea floor for prey (Krutzen et al. 2005). This foraging technique is behaviorally transmitted, mainly from mother to daughter (Krutzen et al. 2005; Bacher et al. 2010), and appears to allow females to exploit a lower quality foraging habitat with no apparent fitness costs (Mann et al. 2008). Therefore, nongenetic inheritance of foraging techniques may help populations cope with environmental change by decreasing feeding competition and facilitating the exploitation of novel food sources. However, behavioral plasticity (and therefore presumably behavioral inheritance) may also slow rather than promote evolutionary change by reducing the genetic covariance between behavioral phenotype and fitness (Huey et al. 2003; Duckworth 2009).

Pollution resistance

Mothers exposed to anthropogenic pollution may transfer resistance to offspring. For example, in the marine bryozoan *Bugula neritina*, mothers exposed to copper (a common marine pollutant from antifouling paints)

produce offspring that are more resistant to copper than larvae from copper-naïve mothers (Marshall 2008). Interestingly, larvae with an induced copper-resistant phenotype were also more resistant to predation by flatworms (Moran et al. 2010), suggesting that nongenetically inherited resistance to pollution may have multiple indirect fitness benefits to offspring. However, offspring from copper-exposed mothers suffered a fitness cost in the absence of copper, showing lower post-metamorphic growth and survival compared with copper-susceptible phenotypes (Marshall 2008). This effect was exacerbated when larvae were exposed to additional environmental stress, with a greater proportion of offspring from copper-naïve mothers surviving low salinity conditions compared with copper-resistant offspring (Moran et al. 2010). Similarly, larval fish from mothers exposed to contaminated sediment were larger and had higher survivorship when also exposed to contaminated sediment, but suffered a fitness cost when reared on reference sediment (Nye et al. 2007). Hence, if current pollution exposure is an accurate predictor of future exposure to pollution, nongenetic transmission of pollution resistance to offspring is likely to help populations persist in an increasingly polluted environment. Conversely, if maternal pollution exposure is a poor predictor of offspring pollution exposure, induced resistance may actually have a detrimental effect on population persistence. The proximate mechanisms mediating these examples of transgenerational plasticity remain to be determined.

Pathological effects of environmental toxins and dietary imbalances

Transgenerational consequences of exposure to environmental stressors and toxins such as fungicides and industrial chemicals have been experimentally demonstrated in rodents and other organisms (see Vandegehuchte and Janssen 2011). Exposure of pregnant rats to endocrine disruptors reduced spermatogenic capacity in male descendants, and this low-fertility phenotype was transmitted through the male line (perhaps via transgenerational epigenetic inheritance) for at least four generations (Anway et al. 2005, 2006b). Moreover, as these males aged, many developed additional diseases including cancer, prostate and kidney disease, and immune system abnormalities (Anway et al. 2006a). Perhaps most surprisingly, F3 descendants exhibited behavioral effects, including altered mate preferences in females (Crews et al. 2007), and altered anxiety levels in both sexes (Skinner et al. 2008). In addition to environmental toxins, both maternal and paternal diet can have transgenerational consequences for offspring health. A chronic high-fat paternal diet in rats caused β -cell dysfunction and thus

impaired glucose-insulin homeostasis in female offspring (Ng et al. 2010). A high-fat maternal diet in mice led to increased body size across two generations of descendants (Dunn and Bale 2009), and the F2 paternal (but not maternal) lineage continued to transmit the increased body size to F3 females (Dunn and Bale 2011). These studies suggest that transgenerational effects of a high-fat diet are carried by a stable germline-based epigenetic mark (Ng et al. 2010; Dunn and Bale 2011). However, surprisingly, while a maternal high-fat diet resulted in reduced insulin sensitivity in the F2 generation of mice (Dunn and Bale 2009), F3 males showed an improved capacity to clear glucose relative to controls (Dunn and Bale 2011). Hence, some traits reverse while other traits persist, suggesting that divergent mechanisms of nongenetic inheritance are involved.

There is mounting evidence of such effects in humans as well. An excess of food during the paternal grandfather's slow growth period (SGP, 9–12 years of age) has been linked to decreased longevity (Bygren et al. 2001) and increased mortality risk of grandsons (Pembrey et al. 2006), whereas a shortage of food during a father's SGP was linked to reduced cardiovascular disease in his sons (Kaati et al. 2002). In addition, early paternal smoking was linked to an increased body mass index in sons (Pembrey et al. 2006). Epimutations in the germline have also been implicated in familial susceptibility to a variety of diseases such as cancer (Gluckman et al. 2007). For example, an epimutation of the tumor suppressor gene *MLH1* was found in both normal somatic tissues and spermatozoa of a patient with multiple cancers, indicating the potential for transmission of the epimutation to offspring (Suter et al. 2004). These studies suggest that exposure to environmental stressors can cause maladaptive transgenerational effects that predispose descendants to pathological states such as obesity, cardiovascular disease, diabetes or cancer.

Considered as a whole, the empirical evidence suggests that, in all organisms, variation in at least some phenotypic traits is transmitted across generations via nongenetic mechanisms of inheritance (Jablonka and Lamb 1995; Bonduriansky and Day 2009). As the aforesaid examples illustrate, such effects can have important consequences for individual fitness. Importantly, nongenetically transmitted phenotypic variants can have a range of effects on fitness. Such variants include facultative modifications (adaptive transgenerational plasticity) such as acquired immunity, parasite resistance or adaptive behavioral variation that are likely to enhance fitness (see Mousseau and Fox 1998), apparently random variations (e.g., in DNA-methylation patterns) that can have positive, neutral or negative effects on fitness, and acquired pathological states induced by toxins, endocrine

disruptors, or dietary imbalances, which will reduce fitness. This diversity in the potential consequences of nongenetic inheritance for offspring fitness reflects the diversity of nongenetic inheritance mechanisms themselves, which range from evolved mechanisms of adaptive transgenerational plasticity to non-adaptive forms of developmental noise (Jablonka and Lamb 1995).

Effects of nongenetic inheritance on offspring fitness may translate into long-term consequences for population persistence and adaptation (Vandegheuchte and Janssen 2011), but long-term predictions pose a challenge. It is reasonable to conjecture that adaptive transgenerational plasticity could allow the mean phenotype to track a rapidly shifting optimum, and thereby enhance a population's probability of persistence. However, like within-generation plasticity, such effects may weaken selection on genetic variation, and thereby affect long-term prospects for genetically based adaptation. Similarly, transmission of acquired pathological states to offspring may reduce recruitment rate and increase probability of extinction in the short term. But such effects may also enhance the efficiency of selection against the most susceptible (e.g., least well-canalized) genotypes, and thereby alter the distribution of breeding values and perhaps affect the course of long-term evolution.

A research program

Further research is needed to illuminate the nature, scope, and importance of nongenetic inheritance in adaptation. We envision research on the evolutionary implications of nongenetic inheritance as a three-stage process. First, experiments in laboratory and field settings can be used to establish which environmental factors can induce transgenerational effects, the consequences of these effects for offspring fitness and, where possible, the proximate basis of the effects. Studies should focus on ecologically relevant factors (Bossdorf et al. 2008) which, in the context of adaptation to rapid environmental change, may be ambient temperature (both mean and variance or range), exposure to a wide range of pollutants (e.g. toxins, hormone-mimics), and changes in species-community composition (e.g. exposure to parasites associated with anthropogenic habitat disturbance). Second, modeling approaches can be used to generate hypotheses about the longer-term consequences of the observed transgenerational effects for population persistence and change over generations in the population-mean phenotype and allele frequencies. Third, multi-generational studies at the population level, including artificial evolution experiments, can be used to test model predictions.

A variety of experimental designs can be used to test for transgenerational effects of environmental factors.

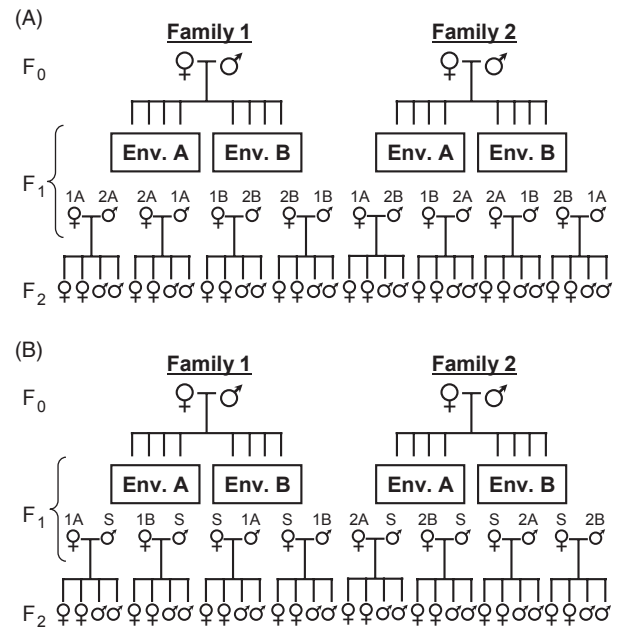

Figure 1 Two designs for split-brood experiments to test for transgenerational effects of an environmental factor (see text for explanation).

Figure 1 shows two variations on the split-brood design, where full-sibs are randomly divided between two or more different environments, and transgenerational effects are assessed by examining the phenotypes of their offspring. Design (a) involves a full range of reciprocal crosses with respect to sex and environment within pairs of families (Family 1 × Family 2, Family 3 × Family 4, etc.), with replication for each type of cross. This is a powerful design for detecting maternal and paternal effects and their interaction. Genetic variation in these effects can also be quantified as the effect of genetic block (family-pair). Design (b) involves crossing individuals reared in different environments with stock partners reared in a neutral or intermediate environment, with replication for each type of cross. This design can be used to test for maternal and paternal effects but not their interaction, and affords considerable power for detecting genetic variation as the effect of family. In either design, interaction effects of parental and offspring environment can be tested by splitting F₂ broods between different environments. Either design can also be implemented using genetically homogeneous lines.

Experiments of this type are likely to generate hypotheses about the proximate mechanisms mediating the observed transgenerational effects, such as transgenerational epigenetic inheritance, somatic inheritance, or behavioral effects. For example, there is mounting evidence that variation in DNA-methylation contributes to heritable

variation in ecologically important traits in plants, and techniques are available for quantifying such variation (Vaughn et al. 2007; Johannes et al. 2009; Roux et al. 2011).

For transgenerational effects identified by experiments, modeling approaches can be used to generate hypotheses about their longer-term consequences for populations. Day and Bonduriansky (2011) outline a general approach for investigating the evolution of traits subject to different mechanisms of inheritance, including Mendelian-genetic inheritance alongside any mechanism of nongenetic inheritance. The model can be adapted to any form of inheritance by specifying three properties: (i) the effects of transmissible variants on individual fitness, (ii) the rules of transmission from parent to offspring, and (iii) any changes that occur in individual phenotypes over an individual lifetime. Incorporating key features of a nongenetic inheritance mechanism alongside genetic inheritance can lead to complex evolutionary dynamics and outcomes that could not be predicted under the assumption of exclusively Mendelian-genetic inheritance (Day and Bonduriansky 2011).

Hypotheses, generated by modeling, about the consequences of nongenetic inheritance for populations can then be tested via longer-term studies on laboratory or natural populations. Such research is already being carried out on transgenerational epigenetic inheritance in plant systems. In *Arabidopsis*, genetically homogeneous lines that vary in epigenetic profile ('epigenetic recombinant inbred lines', or epiRILs) are being used to investigate the heritability of ecologically important traits via the transmission of methylation patterns from parents to offspring (Johannes et al. 2009; Roux et al. 2011). Attempts are also being made to relate this artificially generated epigenetic variation, and its consequences for phenotypic variation and heritability, to naturally occurring epigenetic variation within and among wild populations of *Arabidopsis* (Vaughn et al. 2007; Roux et al. 2011). EpiRILs can, in principle, be created in other organisms (Johannes and Colomé-Tatché 2011), and employed in artificial evolution experiments where replicate genetically homogeneous populations harboring epigenetic variation are subjected to contrasting environments over multiple generations to assess the potential for adaptation (i.e., adaptive change in the population-mean phenotype) via nongenetic inheritance alone. Data from such experiments can be analyzed using extensions of quantitative-genetic theory (Tal et al. 2010; Johannes and Colomé-Tatché 2011). Even more ambitiously, it is now possible to begin to assess the contribution of epigenetic variation to variation in fitness among individuals in natural populations (Visser 2008; Herrera and Bazaga 2011). Equivalent techniques can be developed and employed to study the evolutionary conse-

quences of other mechanisms of nongenetic inheritance as well. A major difficulty that all such studies must overcome is the problem of distinguishing effects of genetic variation (e.g., new mutations) from those of nongenetically transmitted variants (Johannes et al. 2009; Roux et al. 2011).

Conclusions

Theoretical and empirical studies suggest that nongenetic inheritance is a potentially important factor in the fate of populations faced with rapid environmental change. Several complications remain to be resolved, however. First, short-term effects of nongenetic inheritance on offspring fitness may not reflect longer-term effects on population persistence and adaptation. Second, empirical evidence points to the nongenetic inheritance of a wide variety of induced pathological states. Such effects, which have not yet been examined in theoretical studies, could accelerate the demise of populations confronted by toxic pollutants or other environmental insults, but also perhaps increase the efficiency of selection against the most susceptible genotypes. Experiments to uncover the range of environmental factors with transgenerational effects, combined with modeling and multi-generational studies on laboratory and natural populations, will illuminate the consequences of nongenetic inheritance for adaptation.

Acknowledgements

We thank the special issue editors for inviting us to contribute this paper. RB and AJC were funded by an Australian Research Council Discovery Grant and Research Council Fellowship (RB), and TD was funded by the Natural Sciences and Engineering Research Council of Canada (NSERC), an NSERC Steacie Fellowship, and the Canada Research Chairs Program.

Literature cited

- Agrawal, A. A., C. Laforsch, and R. Tollrian. 1999. Transgenerational induction of defences in animals and plants. *Nature* **401**:60–63.
- Aisner, R., and J. Terkel. 1992. Ontogeny of pine cone opening behavior in the black rat, *Rattus rattus*. *Animal Behaviour* **44**:327–336.
- Anway, M. D., A. S. Cupp, M. Uzumcu, and M. K. Skinner. 2005. Epigenetic transgenerational actions of endocrine disruptors and mate fertility. *Science* **308**:1466–1469.
- Anway, M. D., C. Leathers, and M. K. Skinner. 2006a. Endocrine disruptor vinclozolin induced epigenetic transgenerational adult-onset disease. *Endocrinology* **147**:5515–5523.
- Anway, M. D., M. A. Memon, M. Uzumcu, and M. K. Skinner. 2006b. Transgenerational effect of the endocrine disruptor

- vinclozolin on male spermatogenesis. *Journal of Andrology* **27**:868–879.
- Bacher, K., S. Allen, A. K. Lindholm, L. Bejder, and M. Krutzen. 2010. Genes or culture: are mitochondrial genes associated with tool use in bottlenose dolphins (*Tursiops* sp.)? *Behavior Genetics* **40**:706–714.
- Baldwin, J. M. 1896. A new factor in evolution. *The American Naturalist* **30**:441–451.
- Blodner, C., C. Goebel, I. Feussner, C. Gatz, and A. Polle. 2007. Warm and cold parental reproductive environments affect seed properties, fitness, and cold responsiveness in *Arabidopsis thaliana* progenies. *Plant Cell Environment* **30**:165–175.
- Blows, M. W., and A. A. Hoffmann. 2005. A reassessment of genetic limits to evolutionary change. *Ecology* **86**:1371–1384.
- Bonduriansky, R., and T. Day. 2009. Nongenetic inheritance and its evolutionary implications. *Annual Review of Ecology, Evolution and Systematics* **40**:103–125.
- Bonduriansky, R., and M. Head. 2007. Maternal and paternal condition effects on offspring phenotype in *Telostylinus angusticollis* (Diptera: Neriidae). *Journal of Evolutionary Biology* **20**:2379–2388.
- Borenstein, E., I. Meilijson, and E. Ruppín. 2006. The effect of phenotypic plasticity on evolution in multipeaked fitness landscapes. *Journal of Evolutionary Biology* **19**:1555–1570.
- Bossdorf, O., and Y. Zhang. 2011. A truly ecological epigenetics study. *Molecular Ecology* **20**:1572–1574.
- Bossdorf, O., C. L. Richards, and M. Pigliucci. 2008. Epigenetics for ecologists. *Ecology Letters* **11**:106–115.
- Bygren, L. O., G. Kaati, and S. Edvinsson. 2001. Longevity determined by paternal ancestors' nutrition during their slow growth period. *Acta Biotheoretica* **49**:53–59.
- Charmantier, A., R. H. McCleery, L. R. Cole, C. Perrins, L. E. B. Kruuk, and B. C. Sheldon. 2008. Adaptive phenotypic plasticity in response to climate change in a wild bird population. *Science* **320**:800–803.
- Chevin, L.-M., R. Lande, and G. M. Mace. 2010. Adaptation, plasticity, and extinction in a changing environment: towards a predictive theory. *PLoS Biology* **8**:e1000357.
- Crean, A. J., and D. J. Marshall. 2009. Coping with environmental uncertainty: dynamic bet hedging as a maternal effect. *Philosophical Transactions of the Royal Society of London. Series B, Biological Sciences* **364**:1087–1096.
- Crews, D., A. C. Gore, T. S. Hsu, N. L. Dangleben, M. Spinetta, T. Schallert, M. D. Anway *et al.* 2007. Transgenerational epigenetic imprints on mate preference. *Proceedings of the National Academy of Sciences of the United States of America* **104**:5942–5946.
- Crill, W. D., R. B. Huey, and G. W. Gilchrist. 1996. Within- and between-generation effects of temperature on the morphology and physiology of *Drosophila melanogaster*. *Evolution* **50**:1205–1218.
- Day, T., and R. Bonduriansky. 2011. A unified approach to the evolutionary consequences of genetic and nongenetic inheritance. *The American Naturalist* **178**:E18–E36.
- Duckworth, R. A. 2009. The role of behavior in evolution: a search for mechanism. *Evolutionary Ecology* **23**:513–531.
- Dunn, G. A., and T. L. Bale. 2009. Maternal high-fat diet promotes body length increases and insulin insensitivity in second-generation mice. *Endocrinology* **150**:4999–5009.
- Dunn, G. A., and T. L. Bale. 2011. Maternal high-fat diet effects on third generation female body size via the paternal lineage. *Endocrinology* **152**:2228–2236.
- Einum, S., and I. A. Fleming. 2004. Environmental unpredictability and offspring size: conservative versus diversified bet-hedging. *Evolutionary Ecology Research* **6**:443–455.
- Gilchrist, G. W., and R. B. Huey. 2001. Parental and developmental temperature effects on the thermal dependence of fitness in *Drosophila melanogaster*. *Evolution* **55**:209–214.
- Gluckman, P. D., M. A. Hanson, and A. S. Beedle. 2007. Non-genomic transgenerational inheritance of disease risk. *Bioessays* **29**:145–154.
- Gomulkiewicz, R., and D. Houle. 2009. Demographic and genetic constraints on evolution. *The American Naturalist* **174**:E218–E229.
- Herrera, C. M., and P. Bazaga. 2011. Untangling individual variation in natural populations: ecological, genetic and epigenetic correlates of long-term inequality in herbivory. *Molecular Ecology* **20**:1675–1688.
- Hoffmann, A. A., and C. M. Sgrò. 2011. Climate change and evolutionary adaptation. *Nature* **470**:479–485.
- Huey, R. B., P. E. Hertz, and B. Sinervo. 2003. Behavioral drive versus Behavioral inertia in evolution: a null model approach. *American Naturalist* **161**:357–366.
- Jablonka, E., and M. J. Lamb. 1995. *Epigenetic Inheritance and Evolution*. Oxford University Press, Oxford, UK.
- Jablonka, E., and M. J. Lamb. 2005. *Evolution in Four Dimensions*. The MIT Press, Cambridge, MA, USA.
- Jablonka, E., M. Lachmann, and M. J. Lamb. 1992. Evidence, mechanisms and models for the inheritance of acquired traits. *Journal of Theoretical Biology* **158**:245–268.
- Jablonka, E., B. Oborny, I. Molnár, É. Kisdi, J. Hofbauer, and T. Czárán. 1995. The adaptive advantage of phenotypic memory in changing environments. *Philosophical Transactions of the Royal Society London B* **350**:133–141.
- Janssen, G. M., G. De Jong, E. N. G. Jooisse, and W. Scharloo. 1988. A negative maternal effect in springtails. *Evolution* **42**:828–834.
- Johannes, F., E. Porcher, F. K. Teixeira, V. Saliba-Colombani, M. Simon, N. Agier, A. Bulski *et al.* 2009. Assessing the impact of transgenerational epigenetic variation on complex traits. *PLoS Genetics* **5**:e1000530.
- Johannes, F., and M. Colomé-Tatché. 2011. Quantitative epigenetics through epigenomic perturbation of isogenic lines. *Genetics* **188**:215–227.
- Kaati, G., L. O. Bygren, and S. Edvinsson. 2002. Cardiovascular and diabetes mortality determined by nutrition during parents' and grandparents' slow growth period. *European Journal of Human Genetics* **10**:682–688.
- Kochanek, J., Y. M. Buckley, R. J. Probert, S. W. Adkins, and K. J. Steadman. 2010. Pre-zygotic parental environment modulates seed longevity. *Austral Ecology* **35**:837–848.
- Krutzen, M., J. Mann, M. R. Heithaus, R. C. Connor, L. Bejder, and W. B. Sherwin. 2005. Cultural transmission of tool use in bottlenose dolphins. *Proceedings of the National Academy of Sciences of the United States of America* **102**:8939–8943.
- Lachmann, M., and E. Jablonka. 1996. The inheritance of phenotypes: an adaptation to fluctuating environments. *Journal of Theoretical Biology* **181**:1–9.
- Laland, K. N., F. J. Odling-Smee, and M. W. Feldman. 1996. The evolutionary consequences of niche construction: a theoretical investigation using two-locus theory. *Journal of Evolutionary Biology* **9**:293–316.
- Laland, K. N., F. J. Odling-Smee, and M. W. Feldman. 1999. Evolutionary consequences of niche construction and their implications for ecology. *Proceedings of the National Academy of Sciences of the United States of America* **96**:10242–10247.
- Laland, K. N., F. J. Odling-Smee, and S. Myles. 2010. How culture shaped the human genome: bringing genetics and the human sciences together. *Nature Reviews Genetics* **11**:137–148.

- Lande, R. 2009. Adaptation to an extraordinary environment by evolution of phenotypic plasticity and genetic assimilation. *Journal of Evolutionary Biology* **22**:1435–1446.
- Lavergne, S., N. Mouquet, W. Thuiller, and O. Ronce. 2010. Biodiversity and climate change: integrating evolutionary and ecological responses of species and communities. *Annual Review of Ecology Evolution and Systematics* **41**:321–350.
- Lloyd Morgan, C. 1896. On modification and variation. *Science* **4**:733–740.
- Lurling, M., and M. Scheffer. 2007. Info-disruption: pollution and the transfer of chemical information between organisms. *Trends in Ecology & Evolution* **22**:374–379.
- Magiafoglou, A., and A. A. Hoffmann. 2003. Cross-generation effects due to cold exposure in *Drosophila serrata*. *Functional Ecology* **17**:664–672.
- Mann, J., B. L. Sargeant, J. J. Watson-Capps, Q. A. Gibson, M. R. Heithaus, R. C. Connor, and E. Patterson. 2008. Why do dolphins carry sponges? *PLoS ONE* **3**:e3868.
- Marshall, D. J. 2008. Transgenerational plasticity in the sea: context-dependent maternal effects across the life history. *Ecology* **89**:418–427.
- Marshall, D. J., R. Bonduriansky, and L. F. Bussiere. 2008. Offspring size variation within broods as a bet-hedging strategy in unpredictable environments. *Ecology* **89**:2506–2517.
- McMahon, S. M., S. P. Harrison, W. S. Armbruster, P. J. Bartlein, C. M. Beale, M. E. Edwards, J. Kattge *et al.* 2011. Improving assessment and modelling of climate change impacts on global terrestrial biodiversity. *Trends in Ecology & Evolution* **26**:249–259.
- Moran, D. T., G. M. Dias, and D. J. Marshall. 2010. Associated costs and benefits of a defended phenotype across multiple environments. *Functional Ecology* **24**:1299–1305.
- Mousseau, T. A., and C. W. Fox. 1998. The adaptive significance of maternal effects. *Trends in Ecology and Evolution* **13**:403–407.
- Ng, S. F., R. C. Y. Lin, D. R. Laybutt, R. Barres, J. A. Owens, and M. J. Morris. 2010. Chronic high-fat diet in fathers programs beta-cell dysfunction in female rat offspring. *Nature* **467**:963–967.
- Nicotra, A. B., O. K. Atkin, S. P. Bonser, A. M. Davidson, E. J. Finnegan, U. Mathesius, P. Poot *et al.* 2010. Plant phenotypic plasticity in a changing climate. *Trends in Plant Science* **15**:684–692.
- Nye, J. A., D. D. Davis, and T. J. Miller. 2007. The effect of maternal exposure to contaminated sediment on the growth and condition of larval *Fundulus heteroclitus*. *Aquatic Toxicology* **82**:242–250.
- Odling-Smee, F. J., K. N. Laland, and M. W. Feldman. 2003. *Niche Construction: The Neglected Process in Evolution*. Princeton University Press, Princeton, NJ, USA.
- Olofsson, H., J. Ripa, and N. Jonzen. 2009. Bet-hedging as an evolutionary game: the trade-off between egg size and number. *Proceedings of the Royal Society B-Biological Sciences* **276**:2963–2969.
- Paenke, I., B. Sendhoff, J. Rowe, and C. Fernando 2007. On the adaptive disadvantage of Lamarckianism in rapidly changing environments. In F. Almeida e Costa., *Advances in Artificial Life*, 9th European Conference on Artificial Life, pages: 355–364, Springer, LNCS, 4648.
- Pál, C. 1998. Plasticity, memory and the adaptive landscape of the genotype. *Proceedings of the Royal Society of London Series B-Biological Science* **265**:1319–1323.
- Pál, C., and I. Miklós. 1999. Epigenetic inheritance, genetic assimilation and speciation. *Journal of Theoretical Biology* **200**:19–37.
- Pembrey, M. E., L. O. Bygren, G. Kaati, S. Edvinsson, K. Northstone, M. Sjöström, J. Golding *et al.* 2006. Sex-specific, male-line transgenerational responses in humans. *European Journal of Human Genetics* **14**:159–166.
- Qvarnström, A., and T. D. Price. 2001. Maternal effects, paternal effects and sexual selection. *Trends in Ecology & Evolution* **16**:95–100.
- Reed, T. E., R. S. Waples, D. E. Schindler, J. J. Hard, and M. T. Kinnison. 2010. Phenotypic plasticity and population viability: the importance of environmental predictability. *Proceedings of the Royal Society of London. Series B* **277**:3391–3400.
- Richards, E. J. 2006. Inherited epigenetic variation – revisiting soft inheritance. *Nature Reviews Genetics* **7**:395–401.
- Richerson, P. J., and R. Boyd. 2005. *Not by Genes Alone: How Culture Transforms Human Evolution*. The University of Chicago Press, Chicago, IL, USA.
- Robertson, S. J., W. B. McGill, H. B. Massicotte, and P. M. Rutherford. 2007. Petroleum hydrocarbon contamination in boreal forest soils: a mycorrhizal ecosystems perspective. *Biological Reviews* **82**:213–240.
- Roux, F., M. Colomé-Tatché, C. Edelist, R. Wardenaar, P. Guerche, F. Hospital, V. Colot *et al.* 2011. Genome-wide epigenetic perturbation jump-starts patterns of heritable variation found in nature. *Genetics* **188**:1015–1017.
- Simons, A. M. 2011. Modes of response to environmental change and the elusive empirical evidence for bet hedging. *Proceedings of the Royal Society B-Biological Sciences* **278**:1601–1609.
- Skinner, M. K., M. D. Anway, M. I. Savenkova, A. C. Gore, and D. Crews. 2008. Transgenerational epigenetic programming of the brain transcriptome and anxiety behavior. *PLoS ONE* **3**:e3745.
- Suter, C. M., D. I. K. Martin, and R. L. Ward. 2004. Germline epimutation of MLH1 in individuals with multiple cancers. *Nature Genetics* **36**:497–501.
- Tal, O., E. Kisdí, and E. Jablonka. 2010. Epigenetic contribution to covariance between relatives. *Genetics* **184**:1037–1050.
- Teixeira, F. K., F. Heredia, A. Sarazin, F. Roudier, M. Boccara, C. Ciaudo, C. Cruaud *et al.* 2009. A role for RNAi in the selective correction of DNA methylation defects. *Science* **323**:1600–1604.
- Vandegheuchte, M. B., and C. R. Janssen. 2011. Epigenetics and its implications for ecotoxicology. *Ecotoxicology* **20**:607–624.
- Vaughn, M. W., M. Tanurdžić, Z. Lippman, H. Jiang, R. Carrasquillo, P. D. Rabinowicz, N. Dedhia *et al.* 2007. Epigenetic natural variation in *Arabidopsis thaliana*. *PLoS Biology* **5**:e174.
- Visser, M. E. 2008. Keeping up with a warming world; assessing the rate of adaptation to climate change. *Proceedings of the Royal Society of London. Series B* **275**:649–659.
- Wcislo, W. T. 1989. Behavioral environments and evolutionary change. *Annual Review of Ecology and Systematics* **20**:137–169.
- West-Eberhard, M. J. 2003. *Developmental Plasticity and Evolution*. Oxford University Press, Oxford, UK.
- Whitlock, M. C. 1995. Variance-induced peak shifts. *Evolution* **49**:252–259.
- Zamudio, K. R., R. B. Huey, and W. D. Crill. 1995. Bigger isn't always better: body size, developmental and parental temperature and male territorial success in *Drosophila melanogaster*. *Animal Behaviour* **49**:671–677.